

HUBER+SUHNER® DATA SHEET

SENCITY® ACCESSORY

FOR SENCITY® RAIL GPS ANTENNA

Rev: F



Sencity Rail Accessory 9091.99.0189

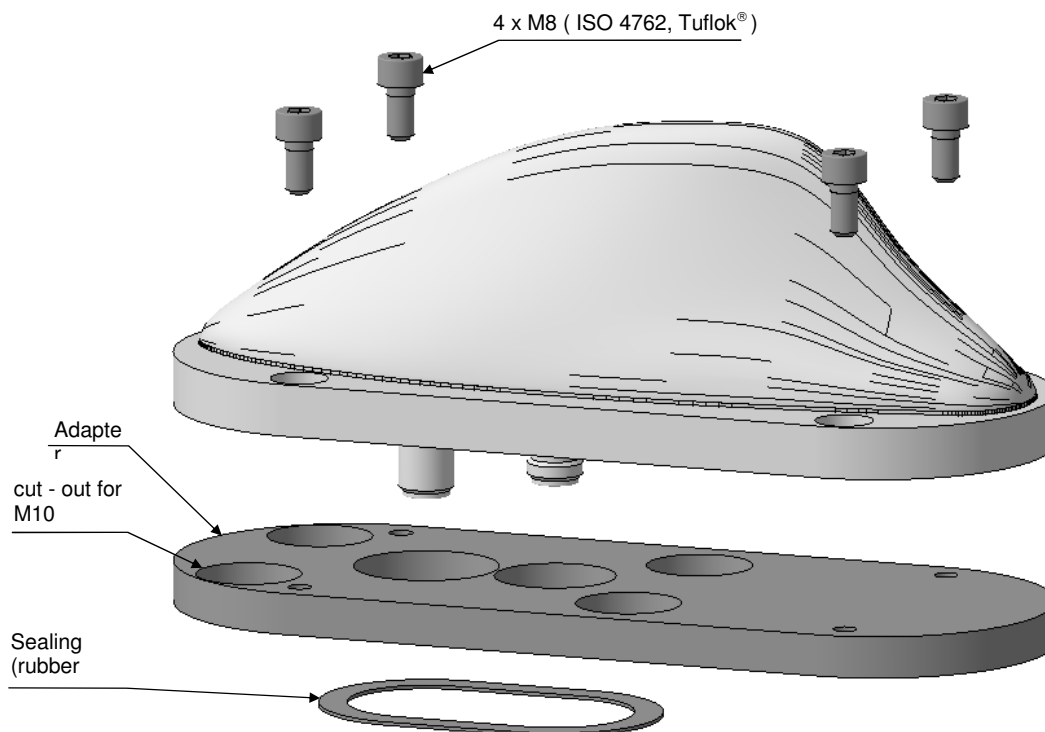

The original mounting hole can be used without any modifications, and a second hole has to be made on the roof for the GPS connector. Using this interface, the mounting holes dimension for the broadband and GPS connectors have to be 17 ... 42 mm and 35 ... 42 mm respectively. Four M8 screws are used to mount the antenna on its adaptor, these will be included within the delivery as standard items. The adaptor panel has to be secured using four M10 screws.

Mechanical Properties	
Dimensions	260 x 100 x 12 mm (10.24" x 3.94" x 0.47")
Weight	0.59 kg (1.31 lbs.)
Housing material	aluminium powder painted RAL 7043 (dark grey)

The adapter panel has been tested in combination with the sencity rail antenna and together met the following requirements:

- Protected against the effects of continuous immersion in water IP68 (only if correctly installed).
- EN 50155, electronic equipment used on rolling stock.
- EN 50124-1, insulation coordination (27.5 KV AC and 3.8 KV DC).
- High voltage and high current protection according to Deutsche Bahn specifications (protection against short circuits of 40 KA).

Available Type	Article no.
9091.99.0189	84008192

Documents	
01.02.0777	security instruction
01.02.1045	mounting instruction



Dimensions (mm)

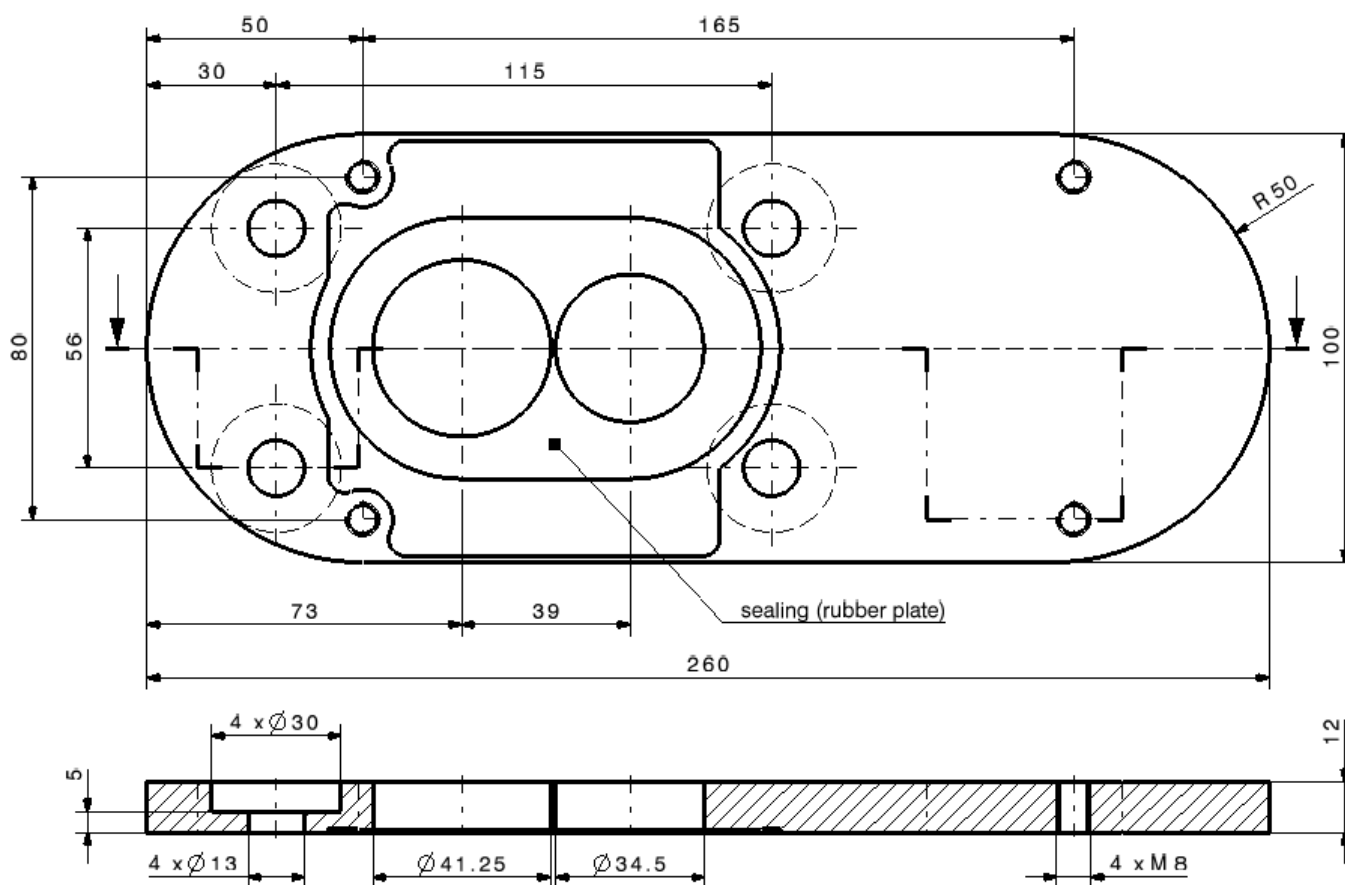

HUBER+SUHNER is certified according to ISO 9001 and ISO 14001

WAIVER!

It is exclusively in written agreements that we provide our customers with warrants and representations as to the technical specifications and/or the fitness for any particular purpose. The facts and figures contained herein are carefully compiled to the best of our knowledge, but they are intended for general informational purposes only.



HUBER+SUHNER AG
RF Industrial
9100 Herisau, Switzerland
Phone +41 (0)71 353 41 11
Fax +41 (0)71 353 45 90
www.hubersuhner.com

HUBER+SUHNER – Excellence in Connectivity Solutions